

Data Needs for Modeling Dehumidification and Cooling Systems

Building America Expert Meeting
June 19, 2009

Hugh I Henderson, Jr., P.E.

CDH Energy Corp.

Cazenovia, NY

www.cdhenergy.com



Overview

- Performance Maps for Components
 - Measured vs. simulated data sources
 - Regression maps vs. other means
 - Empirical vs. semi-empirical
- Representing Different Types of Systems
 - Best independent variable (RH, DPT, WB, etc)
- Equipment Controls and Configuration
 - Change state in response to environment, loading, or state of other equipment
 - Arrangement of multiple components in system
 - Equipment-building interactions

Simulation Framework

model from Henderson and Sand (2003)

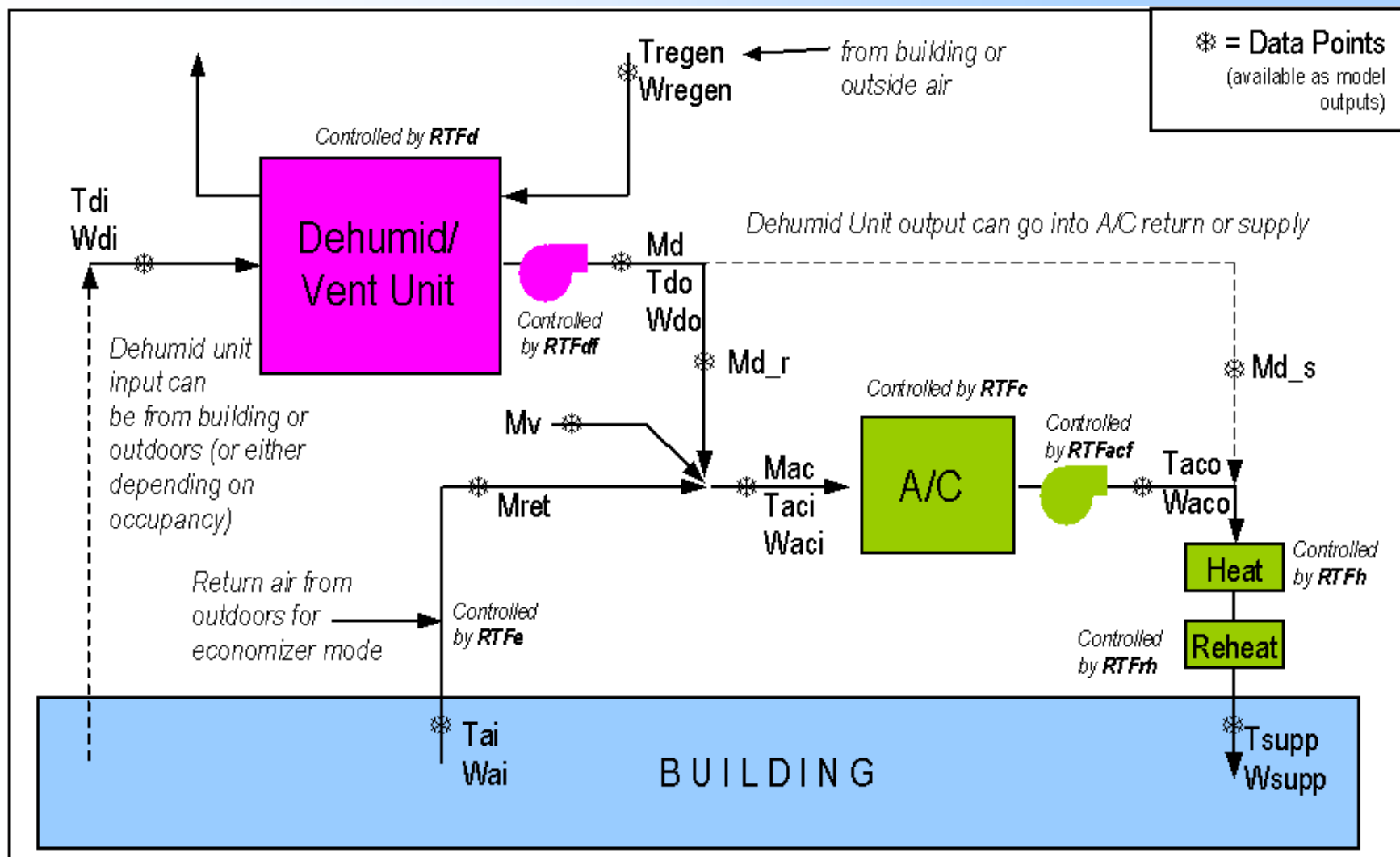

Developing Performance Maps

- Choose best dependent variables
 - Leaving conditions (T & w)
 - Total, Latent and sensible capacity
 - Usually need 3 variables to fully describe a AC or DH capacity & efficiency
- Choose best independent variables
 - Humidity: dew pt, RH, humidity ratio, WB
 - What provides the best fit
 - Physical performance expectations
 - E.g., Total Capacity = $F(WB) \neq F(DB, WB)$

Typical Performance Map

$$T_{po} = c_0 + c_1 * T_{pi} + c_2 * w_{pi} + c_3 * T_{pi}^2 + c_4 * w_{pi}^2$$

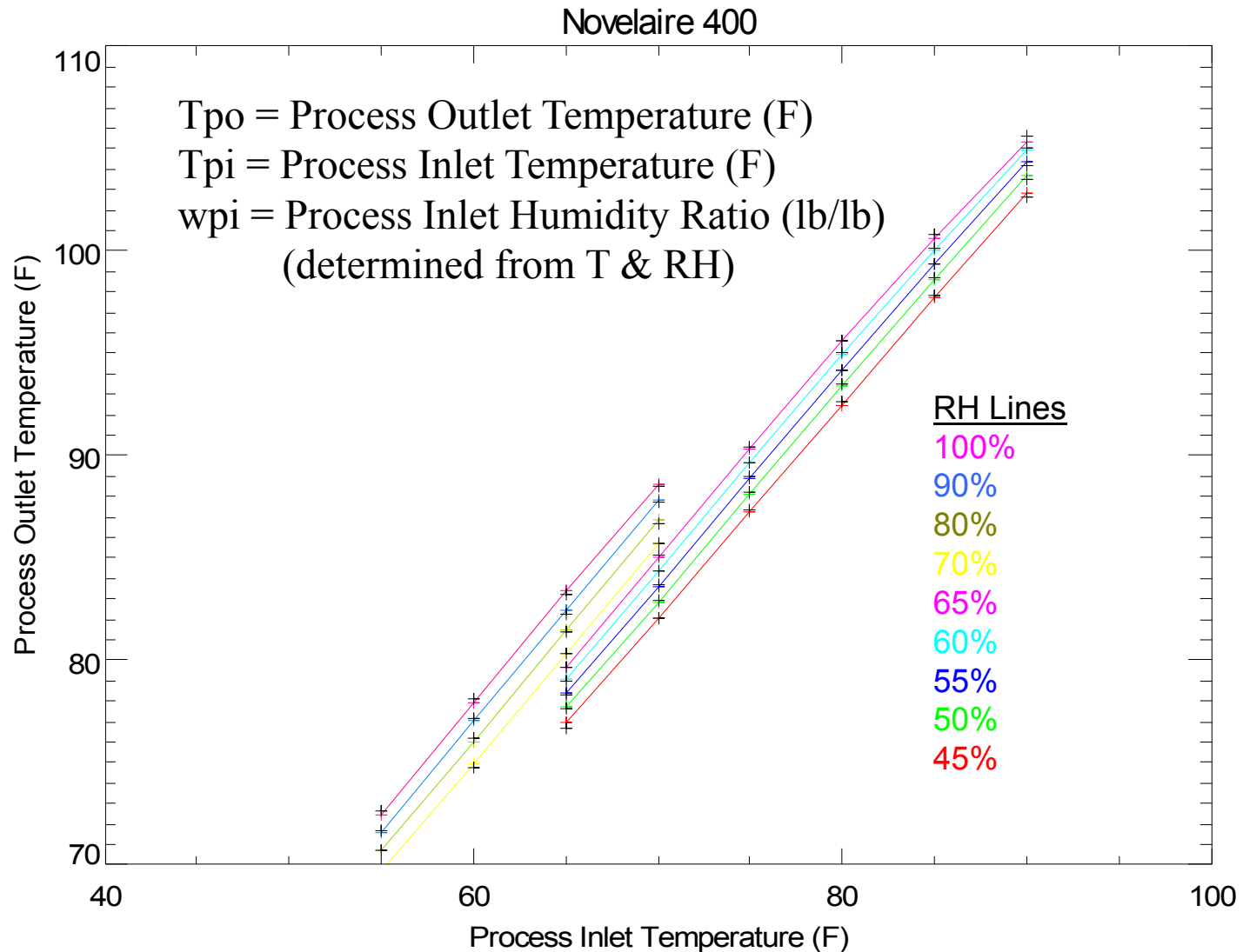

How Good is the Resulting Model?

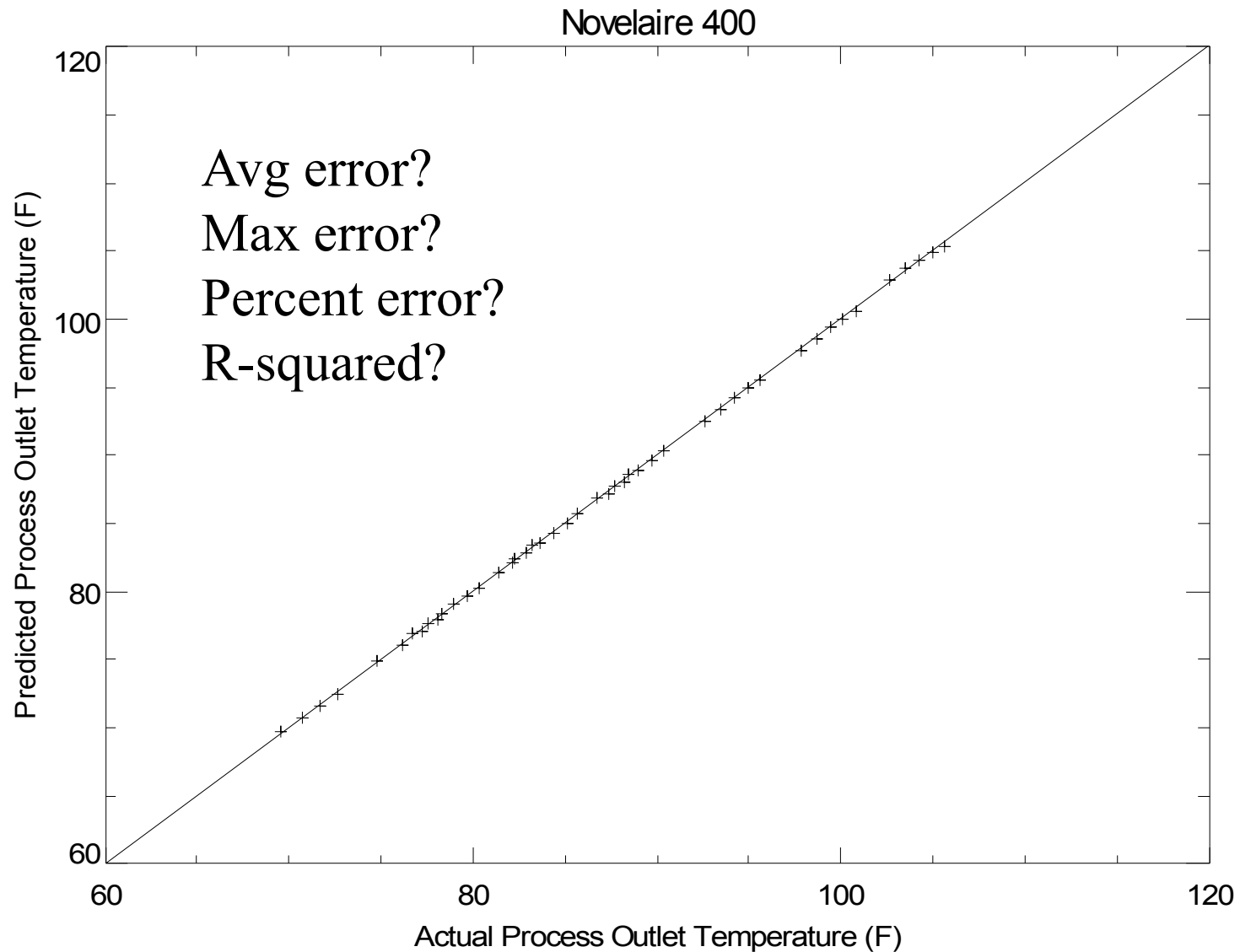

Slightly Non-Physical Behavior

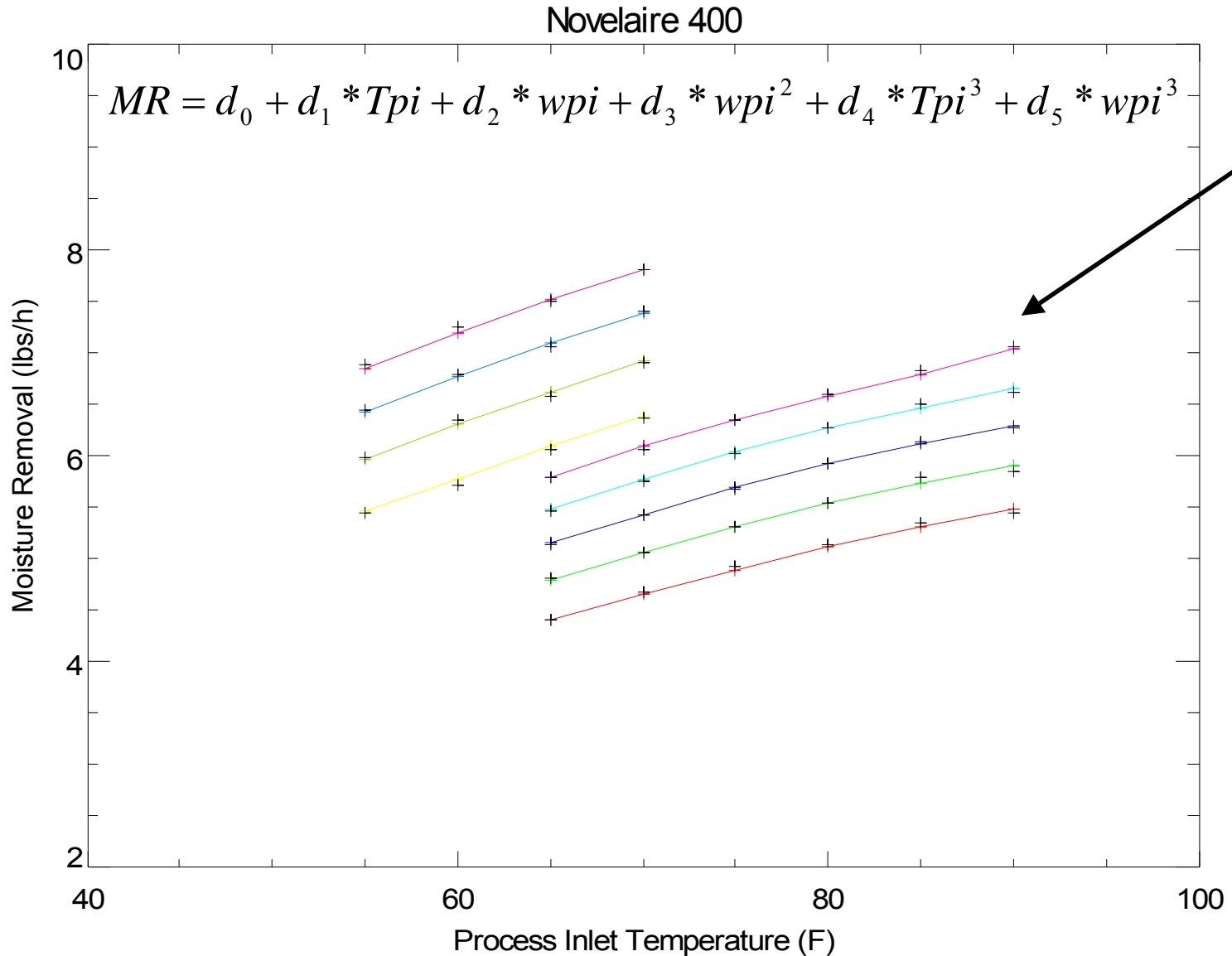

Range of Inlet Conditions

How will the Component Be Applied?

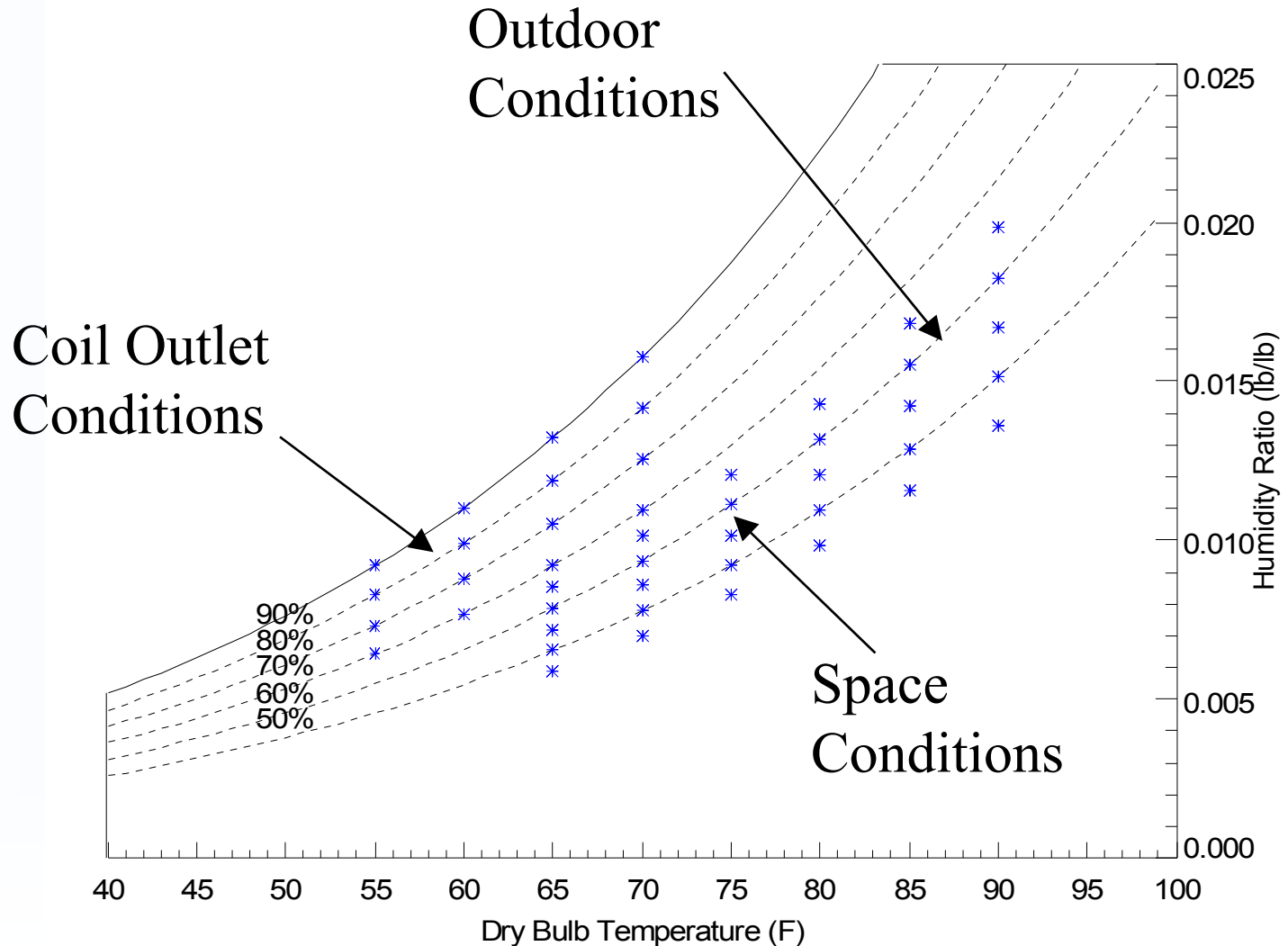

How Comprehensive is The Performance Map?

- Apply to all configurations?
 - inlet from space, from outdoors, from coil outlet
- Various airflows and hardware options
 - different air flows, imbalanced flows, regeneration temperatures, wheel thicknesses
- Can it be normalized to represent different sizes?
 - same model applies for 1, 5, or 50 tons?

Different Products – Different Needs

- Easy: Stand-alone Dehumidifier
 - Ductless = constant air flow, operates at space conditions
 - Few possibilities, easy to make a map
- Harder: Commercial Desiccant Unit
 - Could pull air from space or from outdoors
 - Could operate at different airflow rates
 - Could have imbalanced flows
 - Regeneration temperatures might be fixed or vary with ambient or loading
 - Controls maintain constant supply air temperature

Manufacturer's Performance Data

Typically Generated with Algorithm

48TF004 (3 TONS)										
Temp (F) Air Entering Condenser (Edb)		Air Entering Evaporator — Cfm/BF								
		900/0.11			1200/0.14			1500/0.17		
		Air Entering Evaporator — Ewb (F)								
		72	67	62	72	67	62	72	67	62
75	TC	42.8	38.9	35.0	44.8	40.8	37.0	45.8	41.9	38.2
	SHC	20.0	24.5	28.7	21.8	27.5	32.8	23.0	30.0	36.0
	kW	2.91	2.81	2.70	2.99	2.88	2.78	3.02	2.92	2.82
85	TC	40.8	36.9	33.3	42.5	38.7	35.0	43.6	39.9	36.1
	SHC	19.4	23.7	27.9	21.0	26.8	31.8	22.6	29.7	35.1
	kW	3.14	3.01	2.90	3.20	3.08	2.97	3.24	3.14	3.02
95	TC	38.7	34.9	31.4	40.4	36.6	33.0	41.4	37.6	34.1
	SHC	18.6	22.9	27.0	20.3	26.0	30.9	22.0	28.8	34.0
	kW	3.35	3.21	3.09	3.42	3.29	3.16	3.47	3.35	3.22
105	TC	36.5	32.8	29.2	38.1	34.3	30.9	39.0	35.2	32.4
	SHC	17.8	22.1	25.9	19.6	25.2	29.8	21.2	28.0	32.3
	kW	3.55	3.41	3.27	3.63	3.49	3.35	3.68	3.54	3.43
115	TC	34.3	30.7	26.9	35.7	32.1	28.8	36.5	32.9	30.6
	SHC	17.0	21.3	24.8	19.0	24.4	28.8	20.5	27.1	30.6
	kW	3.76	3.60	3.45	3.84	3.68	3.54	3.88	3.74	3.64

Source of Data

- Virtually all manufacturers publish “simulated” performance data
 - There is no rating standard for how to present this data
- Only rating points are fully based on measured data
- Is this a bad thing?
 - Mature, well understood products may not need measured data for every point in a performance table or map
 - There is a difference between certified data, published data, and “just” data

ORNL AC Model

- Best approach might blend a mix of laboratory tests and simulated data
- Use model to fill in gaps

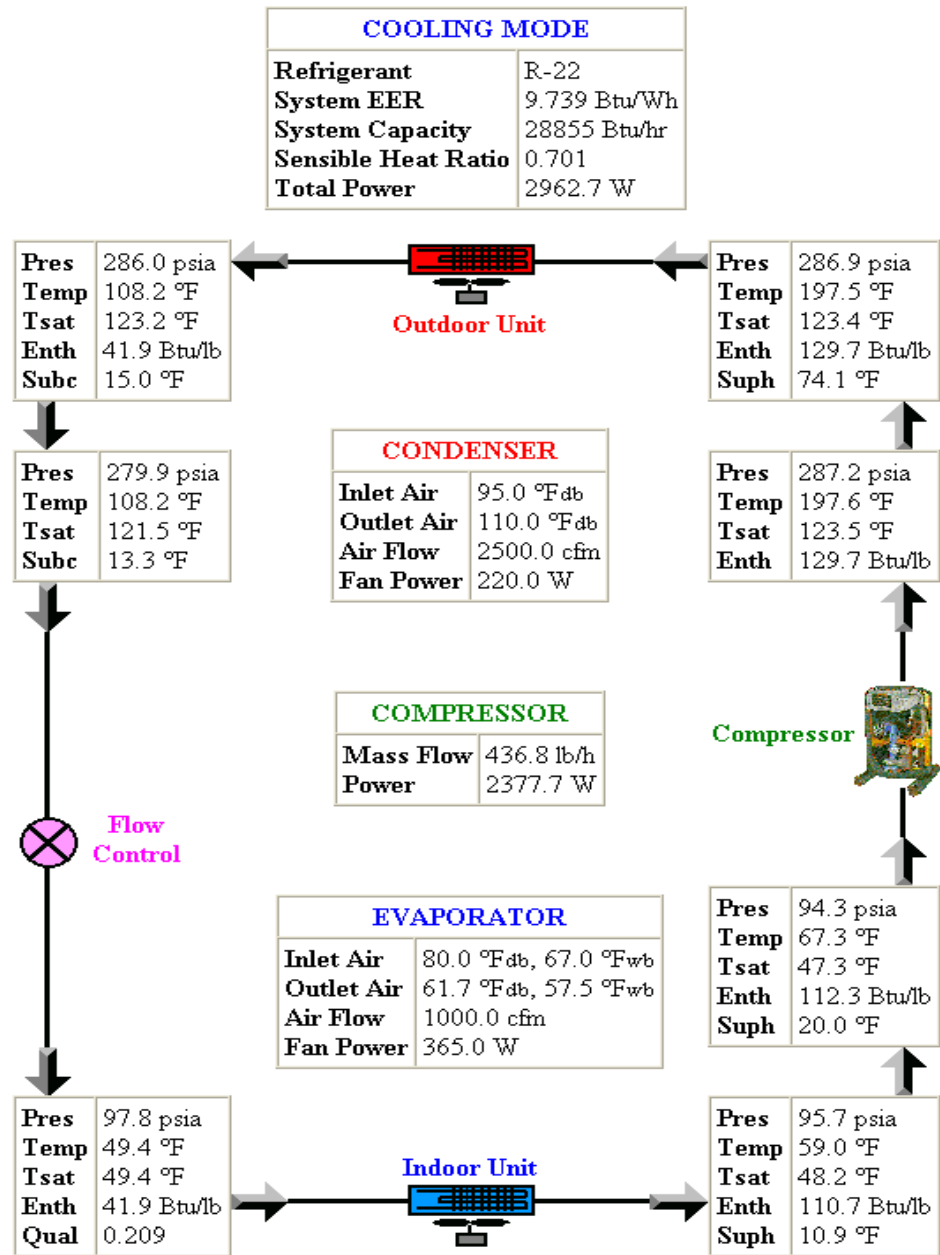

Semi-Empirical Model: AC

- Empirical
 - $QT/QT_{\text{rated}} = F(\text{DBO}, \text{WBI}, \text{CFM}_{\text{ton}})$
 - $\text{kW}/\text{kW}_{\text{rated}} = F(\text{DBO}, \text{WBI}, \text{CFM}_{\text{ton}})$
- Find sensible and latent breakout with physical model
 - Use apparatus dew point and bypass factor (ADP/BF) method; predicts coil dryout
 - Use rated SHR to find “rated” BF
- Then build entire performance map from one rating point

ADP/BF Approach

$$BF = \frac{(T_o - T_{adp})}{(T_i - T_{adp})} = F(\text{cfm})$$

Know BF and Δh ;
iterate to find ADP

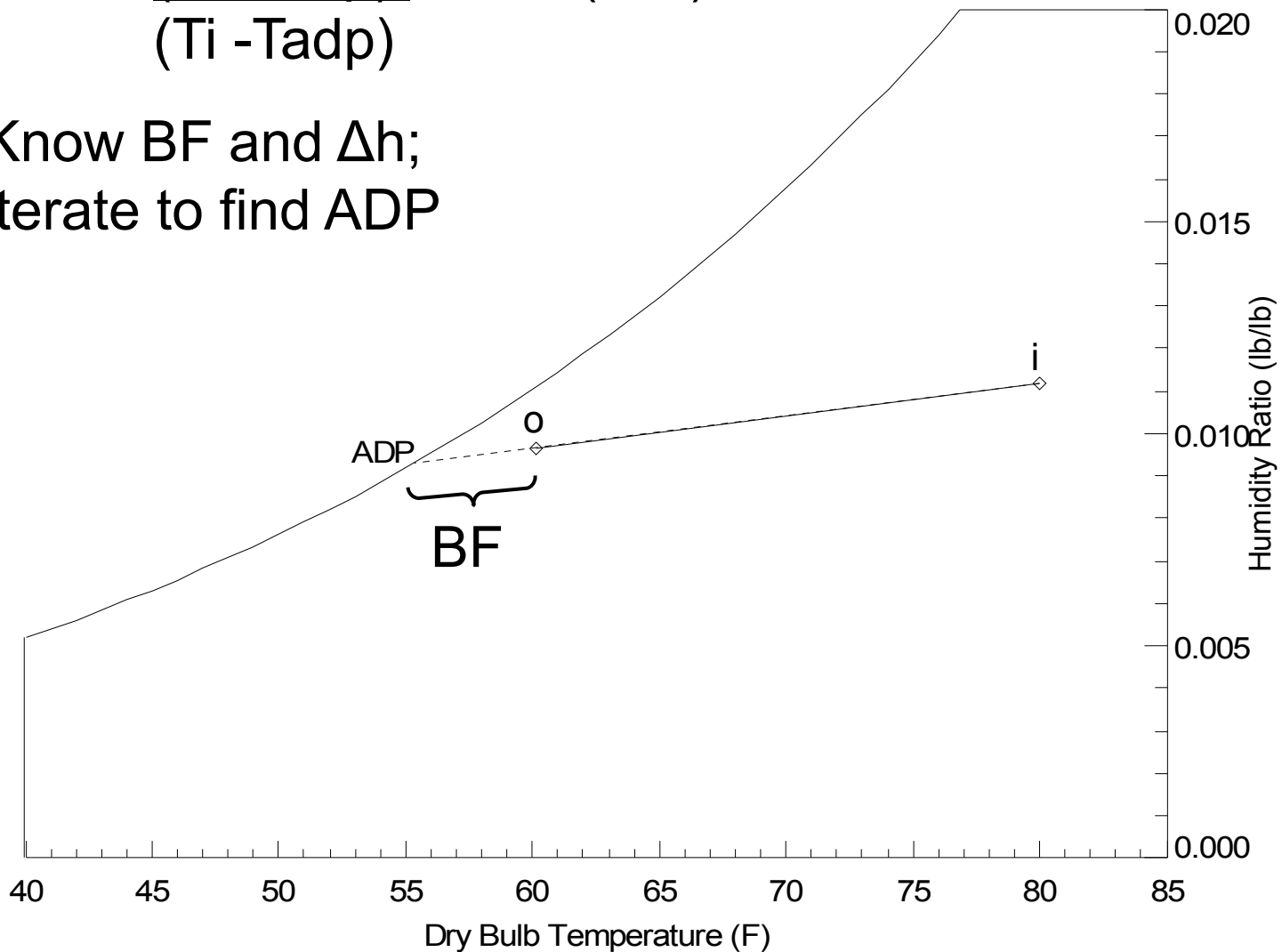

Equipment with Different States

Integrating control issues

- Examples
 - Subcool/reheat systems, hybrid desiccant units, condenser reheat systems
- Component changes “state”
 - Switch between multiple performance maps
- What drives “state” change
 - Ambient temperature (easy)
 - Space conditions (when space is “overcooled”)
 - State of other components (change state when AC is on)

Iterations
required

Easy or Hard: Condenser Reheat

- Simple Way (desuperheating reheat):
 - Use AC performance map
 - Some condenser heat is added into air stream
 - Probably works for small amounts of reheat
 - Reheat does not change AC coil performance
- Hard Way (full condensing):
 - As more reheat is used, AC performance changes (condensing temperature changes)
 - More complicated with modulating
 - Continuous function or 2-3 state maps?

Possible Configurations

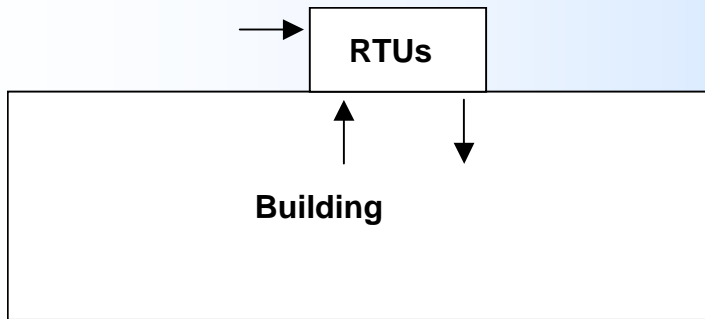

AC Only

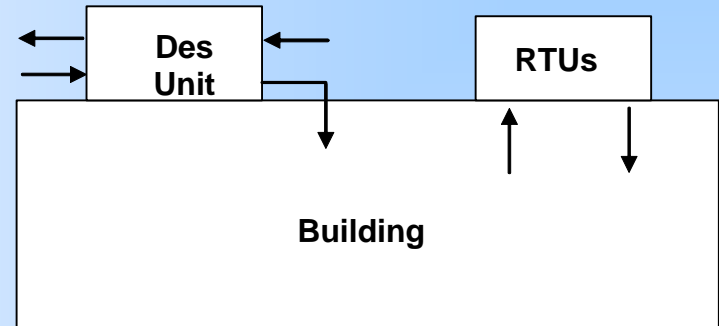

AC w/ DH venting

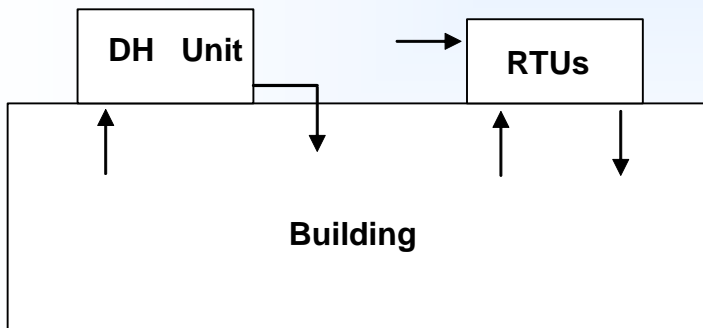

AC w/ DH

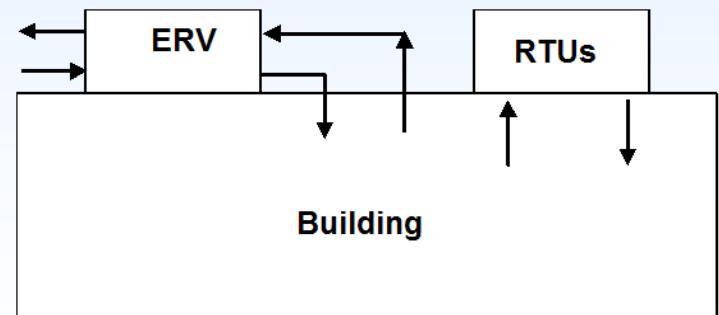

AC w/ ERV

Component Configuration Issues

- Novelaire suggests putting desiccant unit in AC supply stream
 - Desiccant likes cold, high RH air
- DH Runs independently
 - DH might see return or supply air conditions.... or in between

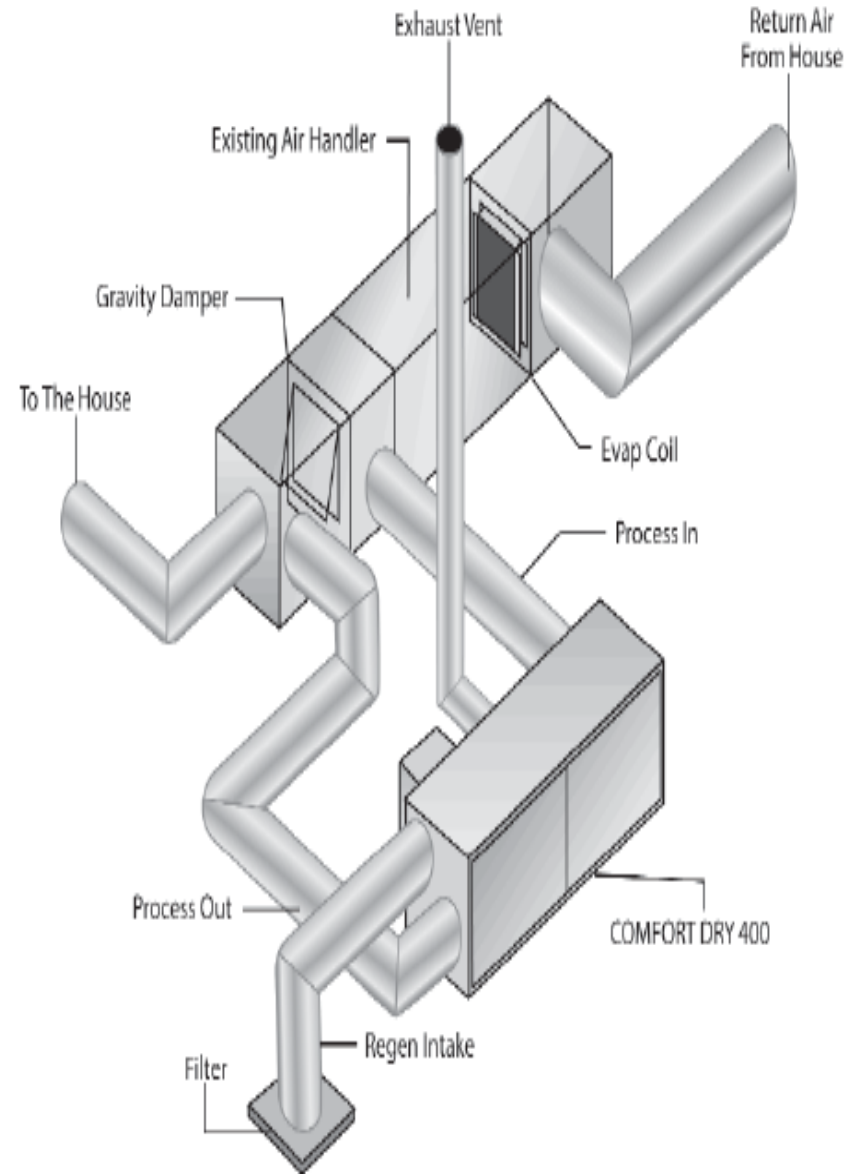

Commercial Hybrid Units

- Can combine multiple components (desiccant, HX, DX coil) into one bigger component
- Integrate some controls into component:
 - Constant supply air set point
 - Hot gas bypass
 - Changes of state (based on no-iterative conditions, e.g., outdoor temperature)

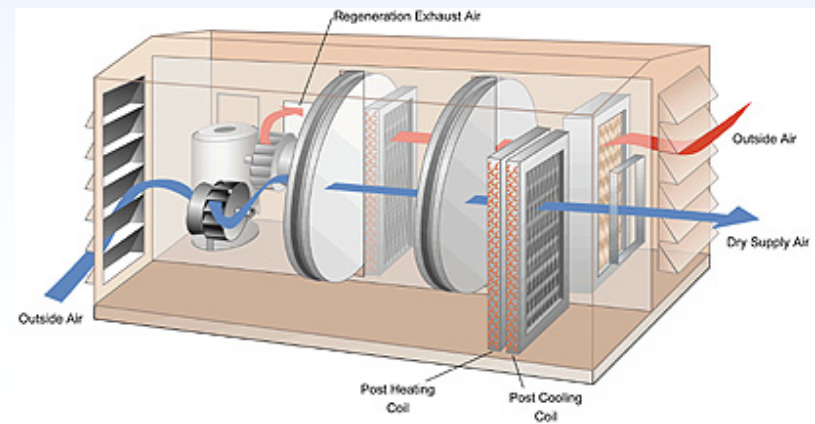
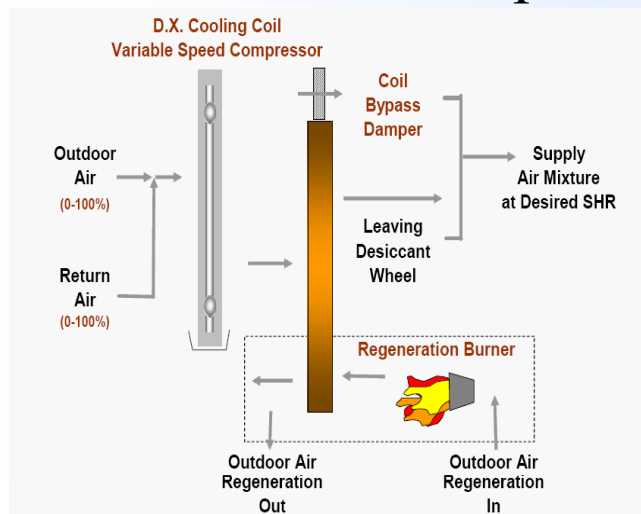

Part-load Load Effects

- Part load efficiency degradation
- Part load latent degradation (i.e., off-cycle moisture evaporation)
- Thermostat “droop”; space temperature changes with loading
- Independent ventilation controls (recycler)
- Hot gas bypass controls

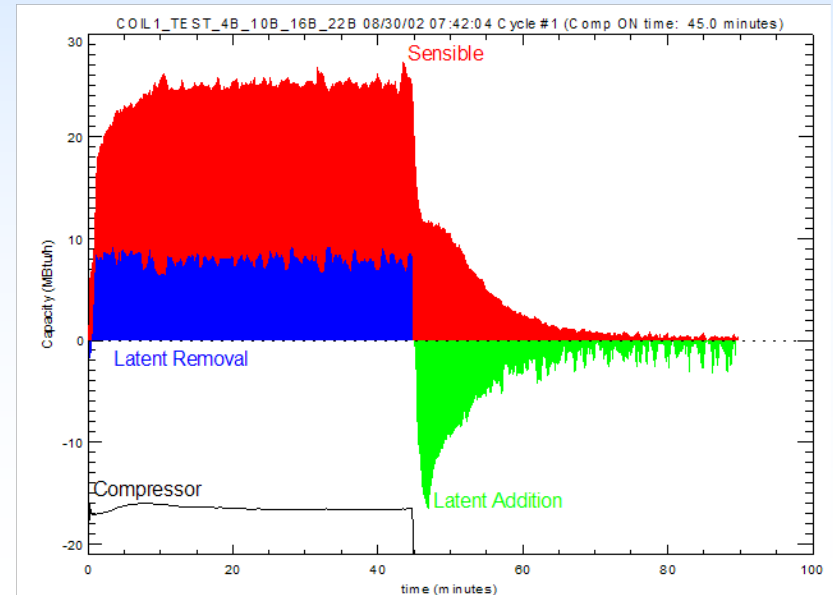

Summary

- Performance for the Component
 - Need data to represent range of expected operating conditions (maybe a mix of measured and simulated)
 - Choose good independent and dependent variables
 - semi-empirical models are better
 - Normalize models where possible
- Integration, Configuration and Control
 - Often the hardest part
 - How component works with other components and within building system